























Bearings	Series	Bore (mm)	Sliding contact surface combination	Relubrication needed	Characteristics	page no
	SI...E SI...ES	5~80	Steel/Steel	Yes	It is made up of a spherical plain radial bearing of type GE...E or GE...ES and body, with female thread.	14
	SA...E SA...ES	5~80	Steel/Steel	Yes	As series SI...E or SI...ES, but with male thread.	15
	SI...T/K	5~30	Steel/PTFE bronze composite	No	It is made up of a maintenance-free spherical-plain radial bearing and rod body, With female thread.	16
	SA...T/K	5~30	Steel/PTFE bronze composite	No	As series SI...T/K but with male thread.	17
	SI...BK	5~30	Steel/PTFE bronze composite	No	Outer ring pressed around inner ring, to line PTFE, material on the surface of spherical plain.	18
	SA...BK	5~30	Steel/PTFE bronze composite	No	As series SI...BK, but with male thread	19
	GIR...UK	6~80	Steel/PTFE bronze composite	No	As series SI...T/K with different dimensions	20
	GAR...UK	6~80	Steel/PTFE bronze composite	No	As series SA...T/K with different dimensions	21

Bearings	Series	Bore(mm)	Sliding contact surface combination	Relubrication needed	Characteristics	page no
	PHS...	6~30	Steel/bronze	Yes	The spherical surface of outer ring with a aluminium-bronze liner lubrication grease nipple and holes.	22
	POS...	5~30	Steel/bronze	Yes	As series PHS...,but with male thread.	23
	SIZP...S	4.83~25.4	Steel/bronze	Yes	The design feature of SIZP...S is as PHS...,but dimensions in inch.	25
	SAZP...S	4.83~25.4	Steel/bronze	Yes	The design feature of SIZP...S is as POS...,but dimensions in inch.	24
	SIZJ...	4.83~19.05	Steel/Steel	Yes	The type SIZJ...is swaged, the dimensions in inch.	25
	SAZJ...	4.83~19.05	Steel/Steel	Yes	The type SAZJ...is swaged, the dimensions in inch.	24
	GIHR...DO	20~120	Steel/Steel	Yes	The housing with a lubrication hole and a grease nipple.	27
	GIHR...K...DO	20~120	Steel/Steel	Yes	As series GIHR...DO, but with locking slot.	26

Bearings	Series	Bore(mm)	Sliding contact surface combination	Relubrication needed	Characteristics	page no
	SIQG...ES	12~125	Steel/Steel	Yes	As series GIHR ...DO , what install inside is GE ...LO series plain bearings.	28
	GK...DO	10~80	Steel/Steel	Yes	There is a dowel pin at the end of the end,and welding slope.	30
	GF...DO	20~120	Steel/Steel	Yes	The type GF ...DO is made up of a spherical plain bearing of type GE ...ES and housing with a rectangular welding base.	29
	SQD...	5~22	Steel/Zinc base alloy	No	Ball joint housing is an outer ring of spherical plain radial bearing made of zinc base alloy.	31
	SOZ...RS	5~22	Steel/Zinc base alloy	No	It's made of zinc base alloy.	32
	SQ...RS	5~22	Steel/Zinc base alloy	No	It's made of zinc base alloy.	33
	1.Tolerances for spherical plain bearings					34-35
	2.Fits of spherical plain bearings					36
	3.Radial internal clearance of spherical plain bearings					37-38
	4.Assembly and lubrication for spherical plain bearings					39-41
	5.Plain bearings compare tabulation					42-47

- Bearing with a stretching rod, stretching rod with right or left-hand female thread.
- It is made up of a spherical plain bearing of type GE...E or GE...ES and rod body.
- To plate zinc on the surface of rod end, the housing of type SI...ES with a lubrication hole and grease nipple.

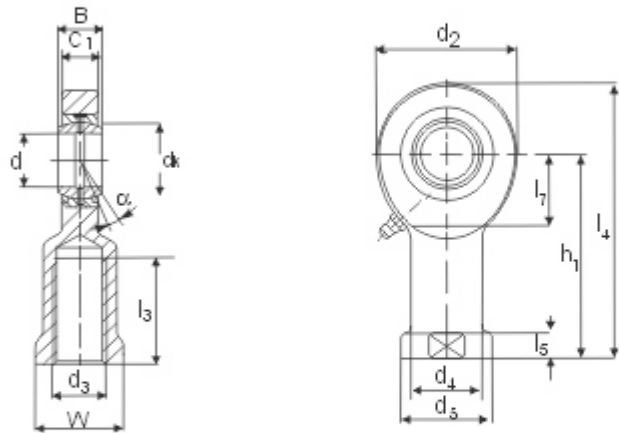

Number	Dimensions (mm)														Load Ratings		weight =kg
	d	d <sub>1</sub>	B	C <sub>max</sub>	l <sub>1</sub> M6	W	d <sub>2</sub> max	h <sub>1</sub>	l <sub>1</sub> max	l <sub>2</sub> max	d <sub>3</sub> max	d <sub>4</sub> max	d <sub>5</sub>	d <sub>6</sub>	a°	C	
SI 6 E	6	M6	6	4.4	11	11	21	30	40.5	5	10	13	10	13	3.40	8.15	0.021
SI 8E	8	M8	8	6	15	14	24	36	48	5	12.5	16	13	15	5.50	12.9	0.039
SI 10 E	10	M10	9	7	20	17	29	43	47.5	6.5	15	19	16	12	8.15	17.6	0.061
SI 12 E	12	M12	10	8	23	19	34	50	67	6.5	17.5	22	18	11	10.8	24.5	0.096
SI 15 ES	15	M14	12	10	30	22	40	61	81	8	21	26	22	8	17.0	36.0	0.18
SI 17 ES	17	M16	14	11	34	27	46	67	90	10	24	30	25	10	21.2	45.0	0.22
SI 20 ES	20	M20X1.5	16	13	40	32	53	77	103.5	10	27.5	35	29	9	30.0	60.0	0.35
SI 25 ES	25	M24X2	20	17	48	36	64	94	126	12	33.5	42	35.5	7	48.0	83.0	0.64
SI 30 ES	30	M30X2	22	19	56	41	73	110	146.5	15	40	50	40.7	6	62.0	110	0.93
SI 35 ES	35	M36X3	25	21	60	50	82	125	166	15	47	58	47	6	80.0	146	1.3
SI 40 ES	40	M39X3	28	23	65	55	92	142	188	18	52	65	53	7	100	180	2.0
SI 45ES	45	M42X3	32	27	65	60	102	145	196	20	58	70	60	7	127	240	2.5
SI 50ES	50	M45X3	35	30	68	65	112	160	216	20	62	75	66	6	156	290	3.5
SI 60 ES	60	M52X3	44	38	70	75	135	175	242.5	20	70	88	80	6	245	450	5.5
SI 70 ES	70	M56X3	49	42	80	85	160	200	280	20	80	98	92	6	315	610	8.6
SI 80 ES	80	M64X4	55	47	85	100	180	230	320	25	95	110	105	6	400	750	12.0

For left-hand thread, suffix "L" is added to bearings number and thread sign, e.g. SI30ES M30X2L-6G, while  $d \geq 15$  it is also made up of a spherical plain bearing with two seals and rod body, e.g. SA25ES-2RS.

- Bearing with a stretching rod, stretching rod with right or left-hand male thread.
- It is made up of a spherical plain bearing of type GE...E or GE...ES and rod body.
- To plate zinc on the surface of rod body, the housing of type SA...ES with a lubrication hole or a grease nipple.

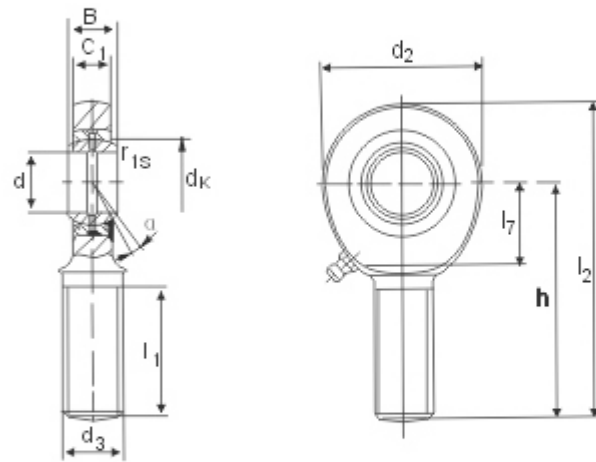

Number	Dimensions (mm)												Load Ratings		weight =kg
	d	d <sub>3</sub>	B	C <sub>max</sub>	l <sub>max</sub>	d <sub>2max</sub>	l <sub>MII</sub>	h	l <sub>max</sub>	d <sub>k</sub>	r <sub>1s</sub> MII	a° ≈	C	Co	
SA 6E	6	M6	6	4.4	18	21	12	36	46.5	10	0.3	13	3.40	8.15	0.017
SA 8E	9	M8	8	6	22	24	14	42	54	13	0.3	15	5.50	12.9	0.029
SA 10 E	10	M10	9	7	26	29	15	48	62.5	16	0.3	12	8.15	17.6	0.051
SA 12 E	12	M12	10	8	28	34	18	54	71	18	0.3	11	10.80	24.5	0.086
SA 15 ES	15	M14	12	10	34	40	20	63	83	22	0.3	8	17.0	36.0	0.14
SA 17 ES	17	M16	14	11	36	46	23	69	92	25	0.3	10	21.2	45.0	0.19
SA 20 ES	20	M20X1.5	16	13	43	53	27	78	104.5	29	0.6	9	30.0	60.0	0.31
SA 25 ES	25	M24X2	20	17	53	64	32	94	126	35.5	0.6	7	48.0	83.0	0.56
SA 30 ES	30	M30X2	22	19	65	73	37	110	146.5	40.7	0.6	6	62.0	110	0.89
SA 35 ES	35	M36X3	25	21	82	82	42	140	181	47	0.6	6	80.0	146	1.4
SA 40 ES	40	M39X3	28	23	86	92	48	150	196	53	0.6	7	100	180	1.8
SA 45ES	45	M42X3	32	27	94	102	52	163	214	60	0.6	7	127	240	2.6
SA 50ES	50	M45X3	35	30	107	112	60	185	241	66	0.6	6	156	290	3.4
SA 60 ES	60	M52X3	44	38	115	135	75	210	277.5	80	1.0	6	245	450	5.9
SA 70 ES	70	M56X4	49	42	125	160	87	235	315	92	1.0	6	315	610	8.2
SA 80 ES	80	M64X4	55	47	140	180	100	270	360	105	1.0	6	400	750	12.0

For left-hand thread, suffix "L" is added to bearings number and thread sign, e.g. SAL30ES M30X2L-6G, while  $d \geq 15$  it is also made up of a spherical plain bearing with two seals and rod body, e.g. SA25ES-2RS.

- Bearing with a stretching rod, stretching rod with right or left-hand female thread.
- It is made up of a spherical plain bearing of type GE...E or GE...ES and rod body.
- To plate zinc on the surface of rod end, the housing of type SI...ES with a lubrication hole and grease nipple.

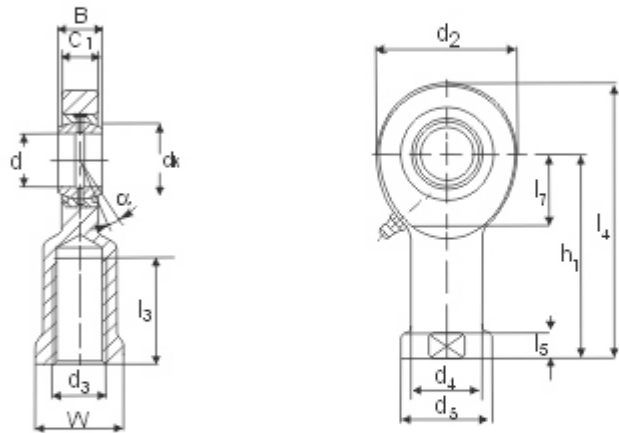

Number	Dimensions (mm)														Load Ratings		weight =kg
	d	d <sub>1</sub>	B	C <sub>max</sub>	l <sub>1</sub> M6	W	d <sub>2</sub> max	h <sub>1</sub>	l <sub>1</sub> max	l <sub>2</sub> max	d <sub>1</sub> max	d <sub>2</sub> max	d <sub>3</sub>	a°	C	Co	
SI 6 E	6	M6	6	4.4	11	11	21	30	40.5	5	10	13	10	13	3.40	8.15	0.021
SI 8E	8	M8	8	6	15	14	24	36	48	5	12.5	16	13	15	5.50	12.9	0.039
SI 10 E	10	M10	9	7	20	17	29	43	47.5	6.5	15	19	16	12	8.15	17.6	0.061
SI 12 E	12	M12	10	8	23	19	34	50	67	6.5	17.5	22	18	11	10.8	24.5	0.096
SI 15 ES	15	M14	12	10	30	22	40	61	81	8	21	26	22	8	17.0	36.0	0.18
SI 17 ES	17	M16	14	11	34	27	46	67	90	10	24	30	25	10	21.2	45.0	0.22
SI 20 ES	20	M20X1.5	16	13	40	32	53	77	103.5	10	27.5	35	29	9	30.0	60.0	0.35
SI 25 ES	25	M24X2	20	17	48	36	64	94	126	12	33.5	42	35.5	7	48.0	83.0	0.64
SI 30 ES	30	M30X2	22	19	56	41	73	110	146.5	15	40	50	40.7	6	62.0	110	0.93
SI 35 ES	35	M36X3	25	21	60	50	82	125	166	15	47	58	47	6	80.0	146	1.3
SI 40 ES	40	M39X3	28	23	65	55	92	142	188	18	52	65	53	7	100	180	2.0
SI 45ES	45	M42X3	32	27	65	60	102	145	196	20	58	70	60	7	127	240	2.5
SI 50ES	50	M45X3	35	30	68	65	112	160	216	20	62	75	66	6	156	290	3.5
SI 60 ES	60	M52X3	44	38	70	75	135	175	242.5	20	70	88	80	6	245	450	5.5
SI 70 ES	70	M56X3	49	42	80	85	160	200	280	20	80	98	92	6	315	610	8.6
SI 80 ES	80	M64X4	55	47	85	100	180	230	320	25	95	110	105	6	400	750	12.0

For left-hand thread, suffix "L" is added to bearings number and thread sign, e.g. SI30ES M30X2L-6G, while  $d \geq 15$  it is also made up of a spherical plain bearing with two seals and rod body, e.g. SA25ES-2RS.

- Bearing with a stretching rod, stretching rod with right or left-hand male thread.
- It is made up of a spherical plain bearing of type GE...E or GE...ES and rod body.
- To plate zinc on the surface of rod body, the housing of type SA...ES with a lubrication hole or a grease nipple.

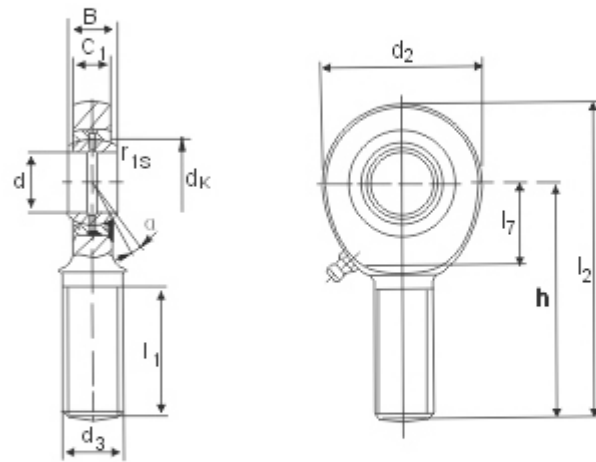

Number	Dimensions (mm)												Load Ratings		weight =kg
	d	d <sub>3</sub>	B	C <sub>max</sub>	l <sub>max</sub>	d <sub>2max</sub>	l <sub>MII</sub>	h	l <sub>max</sub>	d <sub>k</sub>	r <sub>1s</sub> MII	a°	C	Co	
SA 6E	6	M6	6	4.4	18	21	12	36	46.5	10	0.3	13	3.40	8.15	0.017
SA 8E	9	M8	8	6	22	24	14	42	54	13	0.3	15	5.50	12.9	0.029
SA 10 E	10	M10	9	7	26	29	15	48	62.5	16	0.3	12	8.15	17.6	0.051
SA 12 E	12	M12	10	8	28	34	18	54	71	18	0.3	11	10.80	24.5	0.086
SA 15 ES	15	M14	12	10	34	40	20	63	83	22	0.3	8	17.0	36.0	0.14
SA 17 ES	17	M16	14	11	36	46	23	69	92	25	0.3	10	21.2	45.0	0.19
SA 20 ES	20	M20X1.5	16	13	43	53	27	78	104.5	29	0.6	9	30.0	60.0	0.31
SA 25 ES	25	M24X2	20	17	53	64	32	94	126	35.5	0.6	7	48.0	83.0	0.56
SA 30 ES	30	M30X2	22	19	65	73	37	110	146.5	40.7	0.6	6	62.0	110	0.89
SA 35 ES	35	M36X3	25	21	82	82	42	140	181	47	0.6	6	80.0	146	1.4
SA 40 ES	40	M39X3	28	23	86	92	48	150	196	53	0.6	7	100	180	1.8
SA 45ES	45	M42X3	32	27	94	102	52	163	214	60	0.6	7	127	240	2.6
SA 50ES	50	M45X3	35	30	107	112	60	185	241	66	0.6	6	156	290	3.4
SA 60 ES	60	M52X3	44	38	115	135	75	210	277.5	80	1.0	6	245	450	5.9
SA 70 ES	70	M56X4	49	42	125	160	87	235	315	92	1.0	6	315	610	8.2
SA 80 ES	80	M64X4	55	47	140	180	100	270	360	105	1.0	6	400	750	12.0

For left-hand thread, suffix "L" is added to bearings number and thread sign, e.g. SAL30ES M30X2L-6G, while  $d \geq 15$  it is also made up of a spherical plain bearing with two seals and rod body, e.g. SA25ES-2RS.

- Bearing with a stretching rod, stretching rod with right or left-hand female thread.
- It is made up of a maintenance-free spherical-plain radial bearing and rod body.
- To plate zinc on the surface of rod body, spherical surface of inner ring with chromium plating.

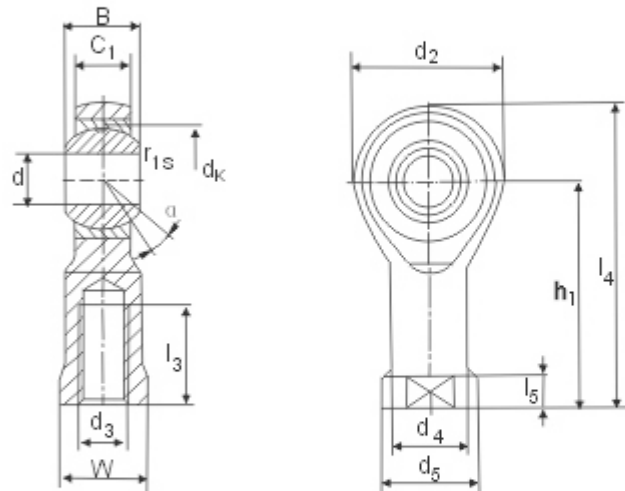

Number	Dimensions (mm)														Load Ratings		weight =kg
	d	d <sub>s</sub>	W	B	C <sub>max</sub>	h <sub>1</sub>	d <sub>max</sub>	l <sub>max</sub>	l <sub>s</sub>	d <sub>max</sub>	d <sub>max</sub>	d <sub>s</sub>	l <sub>min</sub>	α°	C	Co	
SI 5T/K	5	M5	9	8	6	27	18	36	4	8.5	12	11.11	8	13	3.25	5.70	0.016
SI 6T/K	6	M6	11	9	6.75	30	20	40	5	10	13	12.7	9	13	4.30	7.20	0.022
SI 8T/K	8	M8	14	12	9	36	24	48	5	12.5	16	15.875	12	14	7.20	11.6	0.047
SI 10T/K	10	M10	17	14	10.5	43	28	57	6.5	15	19	19.05	15	13	10.0	114.5	0.077
SI 12T/K	12	M12	19	16	12	50	32	66	6.5	17.5	22	22.225	18	13	13.4	17.0	0.10
SI 14T/K	14	M14	22	19	13.5	57	36	75	8	20	26	25.4	21	16	17.0	24.0	0.16
SI 16T/K	16	M16	24	21	15	64	40	84	8	22	28	28.575	24	15	21.6	28.5	0.22
SI 18T/K	18	M18×1.5	27	23	16.5	71	44	93	10	25	31	31.7	27	15	26.0	42.5	0.32
SI 20T/K	20	M20×1.5	30	25	18	77	48	101	10	27.5	35	34.925	30	14	31.5	42.5	0.42
SI 22T/K	22	M22×1.5	32	28	20	84	54	111	12	30	38	38.10	32	15	38.0	57.0	0.54
SI 25T/K	25	M24×2	36	31	22	94	60	124	12	33.5	42	42.85	36	15	47.5	68.0	0.72
SI 28T/K	28	M27×2	41	35	24	103	66	136	14	37	46	47.6	41	15	55.0	75.5	0.82
SI 30T/K	30	M30×2	46	37	25	110	70	145	15	40	50	50.8	45	17	64.0	88.0	1.10

For left-hand thread, suffix "L" is added to bearings number and thread sign, e.g. SI18T/K M18L-6H



- Bearing with a stretching rod, stretching rod with right or left-hand female thread.
- It is made up of a maintenance-free spherical-plain radial bearing and rod body.
- To plate zinc on the surface of rod-end, spherical of inner with chromium plating.

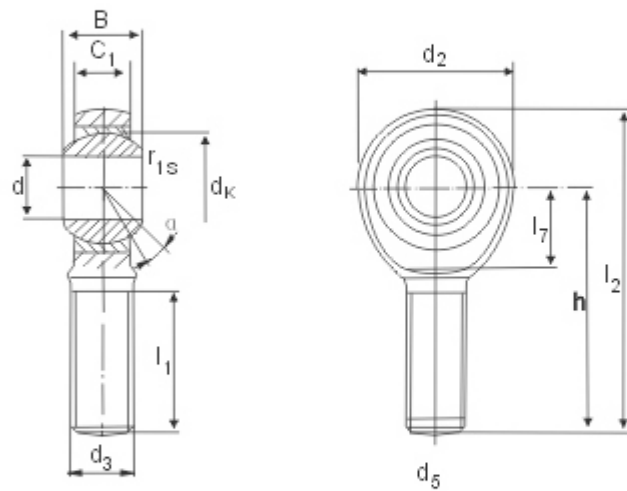

Number	Dimensions(mm)												Load Ratings		weight =kg
	d	d <sub>5</sub>	B	C <sub>max</sub>	l <sub>ml</sub>	d <sub>max</sub>	l <sub>ml</sub>	h	l <sub>max</sub>	d <sub>s</sub>	r <sub>1s</sub> ml	α°	C	Co	
SA 5T/K	5	M5	8	6	19	18		33	42	11.11	0.3	13	3.25	3.10	0.013
SA 6T/K	6	M6	9	6.75	21	20		36	46	12.7	0.3	13	4.30	4.40	0.020
SA 8T/K	8	M8	12	9	25	24		42	54	15.875	0.3	14	7.20	8.00	0.038
SA 10T/K	10	M10	14	10.5	28	28		48	62	19.05	0.3	13	10.0	12.9	0.055
SA 12T/K	12	M12	16	12	32	32		54	70	22.225	0.3	13	13.4	17.0	0.085
SA 14T/K	14	M14	19	13.5	36	36	18	60	78	25.4	0.3	16	17.0	24.0	0.14
SA 16T/K	16	M16	21	15	37	40	23	66	86	28.575	0.3	15	21.6	28.5	0.21
SA 18T/K	18	M18×1.5	23	16.5	41	44	25	72	95	31.75	0.3	15	26.0	42.5	0.28
SAI 20T/K	20	M20×1.5	25	18	45	48	26	78	102	34.925	0.3	14	31.5	42.5	0.38
SA 22T/K	22	M22×1.5	28	20	48	54	29	84	111	38.10	0.3	15	38.0	57.0	0.48
SA 25T/K	25	M24×2	31	22	55	60	32	94	124	42.85	0.3	15	47.5	68.0	0.64
SA 28T/K	28	M27×2	35	24	62	66	34	103	136	47.6	0.3	15	55.0	75.5	0.80
SA 30T/K	30	M30×2	37	25	66	70	37	110	145	50.8	0.3	17	64.0	88.0	1.1

For left-hand thread, suffix "L" is added to bearings number and thread sign, e.g. SAL8T/K M8L--6g

- Bearing with a stretching rod, stretching rod with right or left-hand female thread.
- To plate zinc on the surface of rod body.
- Outer ring pressed around inner ring, to line SF1 material on the surface of spherical plain.

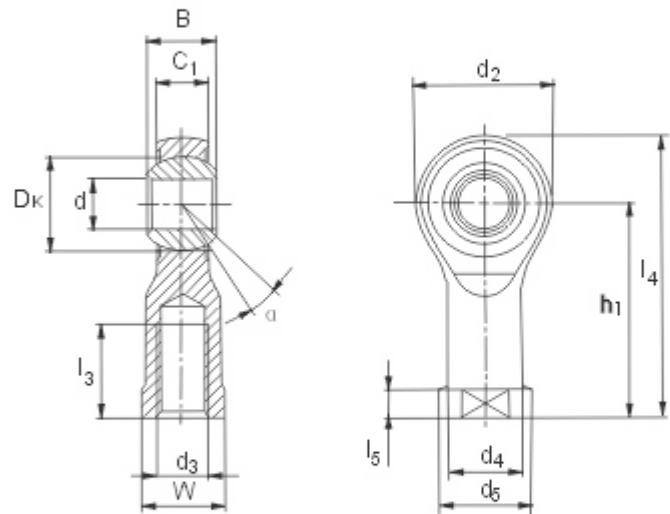

Number	Dimensions (mm)														Load Ratings		weight =kg
	d	d <sub>s</sub>	W	B	C <sub>max</sub>	h <sub>1</sub>	d <sub>max</sub>	l <sub>max</sub>	l <sub>s</sub>	d <sub>max</sub>	d <sub>max</sub>	d <sub>s</sub>	l <sub>min</sub>	α°	C	Co	
SI 5BK	5	M5	9	8	6	27	18	36	4	8.5	12	11.11	8	13	3.25	5.70	0.016
SI 6BK	6	M6	11	9	6.75	30	20	40	5	10	13	12.7	9	13	4.30	7.20	0.022
SI 8BK	8	M8	14	12	9	36	24	48	5	12.5	16	15.875	12	14	7.20	11.6	0.047
SI 10BK	10	M10	17	14	10.5	43	28	57	6.5	15	19	19.05	15	13	10.0	14.5	0.077
SI 12BK	12	M12	19	16	12	50	32	66	6.5	17.5	22	22.225	18	13	13.4	17.0	0.10
SI 14B/K	14	M14	22	19	13.5	57	36	75	8	20	26	25.4	21	16	17.0	24.0	0.16
SI 16BK	16	M16	24	21	15	64	40	84	8	22	28	28.575	24	15	21.6	28.5	0.22
SI 18BK	18	M18×1.5	27	23	16.5	71	44	93	10	25	31	31.7	27	15	26.0	42.5	0.32
SI 20BK	20	M20×1.5	30	25	18	77	48	101	10	27.5	35	34.925	30	14	31.5	42.5	0.42
SI 22BK	22	M22×1.5	32	28	20	84	54	111	12	30	38	38.10	32	15	38.0	57.0	0.54
SI 25BK	25	M24×2	36	31	22	94	60	124	12	33.5	42	42.85	36	15	47.5	68.0	0.72
SI 28BK	28	M27×2	41	35	24	103	66	136	14	37	46	47.6	41	15	55.0	75.5	0.82
SI 30BK	30	M30×2	46	37	25	110	70	145	15	40	50	50.8	45	17	64.0	88.0	1.10

For left-hand thread, suffix "L" is added to bearings number and thread sign, e.g. SI16BK M16L-6H

- Bearing with a stretching rod, stretching rod with right or left-hand female thread.
- To plate zinc on the surface of rod body.
- Outer ring pressed around inner ring, to line SF1 material on the surface of spherical plain.

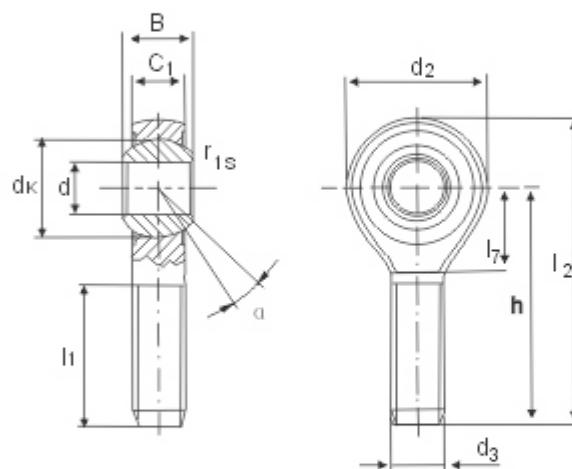

Number	Dimensions (mm)												Load Ratings		weight =kg
	d	d <sub>s</sub>	B	C <sub>max</sub>	l <sub>ml</sub>	d <sub>max</sub>	l <sub>ml</sub>	h	l <sub>max</sub>	d <sub>s</sub>	r <sub>1s</sub> ml	a°	C	Co	
SA 5BK	5	M5	8	6	19	18		33	42	11.11	0.3	13	3.25	3.10	0.013
SA 6BK	6	M6	9	6.75	21	20		36	46	12.7	0.3	13	4.30	4.40	0.020
SA 8BK	8	M8	12	9	25	24		42	54	15.875	0.3	14	7.20	8.00	0.038
SA 10BK	10	M10	14	10.5	28	28		48	62	19.05	0.3	13	10.0	12.9	0.055
SA 12BK	12	M12	16	12	32	32		54	70	22.225	0.3	13	13.4	17.0	0.085
SA 14BK	14	M14	19	13.5	36	36	18	60	78	25.4	0.3	16	17.0	24.0	0.14
SA 16BK	16	M16	21	15	37	40	23	66	86	28.575	0.3	15	21.6	28.5	0.21
SA 18BK	18	M18×1.5	23	16.5	41	44	25	72	95	31.7	0.3	15	26.0	42.5	0.28
SA 20BK	20	M20×1.5	25	18	45	48	26	78	102	34.925	0.3	14	31.5	42.5	0.38
SA 22BK	22	M22×1.5	28	20	48	54	29	84	111	38.10	0.3	15	38.0	57.0	0.48
SA 25BK	25	M24×2	31	22	55	60	32	94	124	42.85	0.3	15	47.5	68.0	0.64
SA 28BK	28	M27×2	35	24	62	66	34	103	136	47.6	0.3	15	55.0	75.5	0.80
SA 30BK	30	M30×2	37	25	66	70	37	110	145	50.8	0.3	17	64.0	88.0	1.1

For left-hand thread, suffix "L" is added to bearings number and thread sign, e.g. SAL8BK M8L-6g

- Bearings with a stretching rod, stretching rod with right or left-hand female thread.
- It is made up of a maintenance-free spherical-plain radial bearing and rod body.
- To plate zinc on the surface of rod body, spherical surface of inner ring with chromium plating.

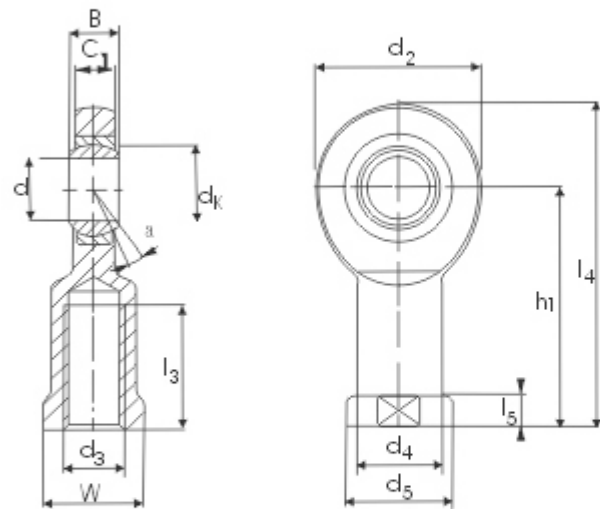

Number	Dimensions (mm)														Load Ratings		weight =kg
	d	d <sub>3</sub>	B	C <sub>max</sub>	d <sub>max</sub>	l <sub>max</sub>	W	d <sub>max</sub>	d <sub>max</sub>	l <sub>max</sub>	h <sub>1</sub>	l <sub>max</sub>	d <sub>k</sub>	α°	C	C <sub>0</sub>	
GIR 6 UK	6	M6	6	4.4	21	11	11	10	13	5	30	40.5	10	13	3.6	8.15	0.021
GIR 8 UK	8	M8	8	6	24	15	14	12.5	16	5	36	48	13	15	5.85	12.9	0.039
GIR 10 UK	10	M10	9	7	29	20	17	15	19	6.5	43	57.5	16	12	8.65	17.6	0.061
GIR 12 UK	12	M12	10	8	34	23	19	17.5	22	6.5	50	67	18	11	11.4	24.5	0.096
GIR 15 UK	15	M14	12	10	40	30	22	21	26	8	61	81	22	8	17.6	36.0	0.18
GIR 17 UK	17	M16	14	11	46	34	27	24	30	10	67	90	25	10	22.4	45.0	0.22
GIR 20 UK	20	M20×1.5	16	13	53	40	32	27.5	35	10	77	103.5	29	9	31.5	60.0	0.35
GIR 25 UK	25	M24×2	20	17	64	48	36	33.5	42	12	94	126	35.5	7	51.0	83.0	0.64
GIR 30 UK	30	M30×2	22	19	73	56	41	40	50	15	110	146.5	40.7	6	66.5	110.0	0.93
GIR 35 UK-2RS	35	M36×3	25	21	82	60	50	47	58	15	125	166	47	6	112	146	1.3
GIR 40 UK-2RS	40	M39×3	28	23	92	65	55	52	65	18	142	188	53	7	140	180	2.0
GIR 45 UK-2RS	45	M42×3	32	27	102	65	60	58	70	20	145	196	60	7	180	240	2.5
GIR 50 UK-2RS	50	M45×3	35	30	112	68	65	62	75	20	160	216	66	6	220	290	3.5
GIR 60 UK-2RS	60	M52×3	44	38	135	70	75	70	88	20	175	242.5	80	6	345	450	5.5
GIR 70 UK-2RS	70	M56×4	49	42	160	80	85	80	98	20	200	280	92	6	440	610	8.6
GIR 80 UK-2RS	80	M64×4	55	47	180	85	100	95	110	25	230	320	105	6	570	750	12.00

For left-hand thread, suffix "L" is added to bearings number and thread sign, e.g. GIL10UK M10L-6H

- Bearings with a stretching rod, stretching rod with right or left-hand female thread.
- It is made up of a maintenance-free spherical plain radial bearing and rod body.
- To plate zinc on the surface of rod body, spherical surface of inner ring with chromium plating.

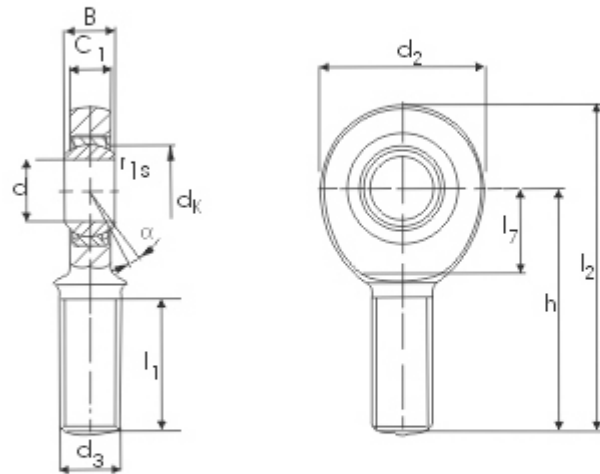

Number	Dimensions (mm)												Load Ratings		weight =kg
	d	d <sub>1</sub>	B	C <sub>max</sub>	d <sub>max</sub>	l <sub>3</sub>	h	l <sub>7</sub>	l <sub>ml</sub>	d <sub>k</sub>	r, S ml	α°	C	C <sub>0</sub>	
GAR 6 UK	6	M6	6	4.4	21	46.5	36	12	18	10	0.3	13	3.6	8.15	0.017
GAR 8 UK	8	M8	8	6	24	54	42	14	22	13	0.3	15	5.85	12.9	0.029
GAR 10 UK	10	M10	9	7	29	62.5	48	15	26	16	0.3	12	8.65	17.6	0.051
GAR 12 UK	12	M12	10	8	34	71	54	18	28	18	0.3	11	11.4	24.5	0.086
GAR 15 UK	15	M14	12	10	40	83	63	20	34	22	0.3	8	17.6	36.0	0.14
GAR 17 UK	17	M16	14	11	46	92	69	23	36	25	0.3	10	22.4	45.0	0.19
GAR 20 UK	20	M20×1.5	16	13	53	104.5	78	27	43	29	0.6	9	31.5	60.0	0.31
GAR 25 UK	25	M24×2	20	17	64	126	94	32	53	35.5	0.6	7	51.0	83.0	0.56
GAR 30 UK	30	M30×2	22	19	73	146.5	110	37	65	40.7	0.6	6	66.5	110	0.89
GAR 35 UK-2RS	35	M36×3	25	21	82	181	140	42	82	47	0.6	6	112	146	1.4
GAR 40 UK-2RS	40	M39×3	28	23	92	196	150	48	86	53	0.6	7	140	180	1.8
GAR 45 UK-2RS	45	M42×3	32	27	102	214	163	52	94	60	0.6	7	180	240	2.6
GAR 50 UK-2RS	50	M45×3	35	30	112	241	185	60	107	66	0.6	6	220	290	3.4
GAR 60 UK-2RS	60	M52×3	44	38	135	277.5	210	75	115	80	1.0	6	345	450	5.9
GAR 70 UK-2RS	70	M56×4	49	42	160	315	235	87	125	92	1.0	6	440	610	8.2
GAR 80 UK-2RS	80	M64×4	55	47	180	360	270	100	140	105	1.0	6	570	750	12.0

For left-hand thread, suffix "L" is added to bearings number and thread sign, e.g. GAL10 UK M10L-6g

- Bearings with a stretching rod, stretching rod with right or left-hand female thread.
- The surface of spherical plain with a bronze liner.
- To plate zinc on the surface of rod body, the housing with a lubrication hole or a grease nipple.

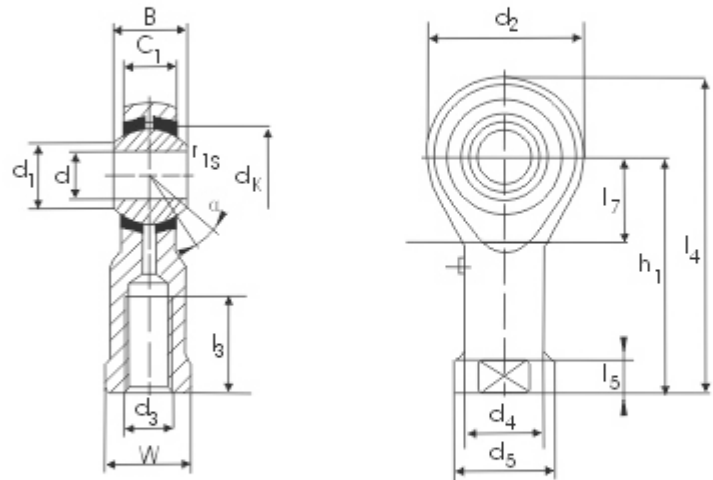

Number	Dimensions (mm)															Load Ratings		weight =kg
	d	d <sub>s</sub>	B	C <sub>max</sub>	W	l <sub>m li</sub>	d <sub>2 max</sub>	l <sub>3 max</sub>	h <sub>1</sub>	l <sub>5 max</sub>	d <sub>3 max</sub>	d <sub>4 max</sub>	d <sub>s</sub>	d <sub>1</sub>	α°	C	Co	
PHS 5	5	M5	8	6	9	14	18	36	27	4	8.5	11	11.11	7.7	13	3.25	5.70	0.016
PHS 6	6	M6	9	6.75	11	14	20	40	30	5	10	13	12.7	9	13	4.30	7.20	0.022
PHS 8	8	M8	12	9	14	17	24	48	36	5	12.5	16	15.875	10.4	4	7.20	11.60	0.047
PHS 10	10	M10	14	10.5	17	21	26	56	43	6.5	15	19	19.05	12.9	13	10.0	14.5	0.077
PHS 12	12	M12	16	12	19	24	30	65	50	6.5	17.5	22	22.225	15.4	13	13.4	17.0	0.10
PHS 14	14	M14	19	13.5	22	27	34	74	57	8	20	26	25.4	16.9	16	17.0	24.0	0.16
PHS 16	16	M16	21	15	24	33	40	84	64	8	22	28	28.575	19.4	15	21.6	28.5	0.22
PHS 18	18	M18×1.5	23	16.5	27	36	44	93	71	10	25	31	31.75	21.9	15	26.0	42.5	0.32
PHS 20	20	M20×1.5	25	18	30	40	48	101	77	10	27.5	35	34.925	24.4	14	31.5	42.5	0.42
PHS 22	22	M22×1.5	28	20	32	43	54	111	84	12	30	38	38.10	25.8	5	38.5	57.0	0.540
PHS 25	25	M24×2	31	22	36	48	60	124	94	12	33.5	42	42.85	29.6	5	47.5	68.0	0.73
PHS 25	25	M27×2	35	24	41	53	66	136	103	14	37	46	47.6	32.3	15	58.0	75.0	0.98
PHS 30	30	M30×2	37	25	46	56	70	145	110	15	40	50	50.8	34.8	17	64.0	88.0	1.1

For left-hand thread, suffix "L" is added to bearings number and thread sign, e.g. PHSL 18 M18X1.5 -6H

- Bearings with a stretching rod, stretching rod with right or left-hand male thread.
- The surface of spherical plain with a bronze liner.
- To plate zinc on the surface of rod body, the housing with a lubrication hole or a grease nipple.

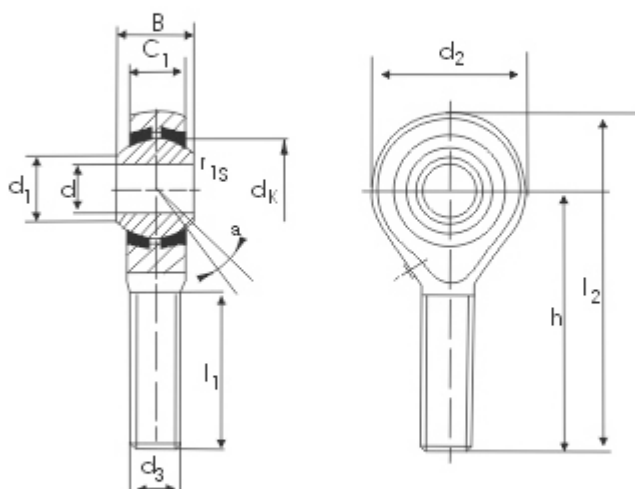

Number	Dimensions (mm)											Load Ratings		weight =kg	
	d	d <sub>s</sub>	B	C <sub>max</sub>	l <sub>ml</sub>	d <sub>max</sub>	h	l <sub>max</sub>	d <sub>k</sub>	r <sub>1s</sub> ml	a°	d <sub>l</sub>	C		Co
POS 5	5	M5	8	6	20	18	33	42	11.11	0.3	13	7.7	3.25	5.7	0.013
POS 6	6	M6	9	6.75	23	20	36	46	12.7	0.3	13	8.9	4.30	7.2	0.020
POS 8	8	M8	12	9	25	24	42	54	15.875	0.3	4	10.3	7.20	11.6	0.030
POS 10	10	M10	14	10.5	30	26	48	61	19.05	0.3	13	12.9	10.0	14.5	0.055
POS 12	12	M12	16	12	34	30	54	69	22.225	0.3	13	15.4	13.4	17.0	0.85
POS 14	14	M14	19	13.5	37	34	60	77	25.4	0.3	16	16.8	17.0	24.0	0.14
POS 16	16	M16	21	15	41	40	66	86	28.575	0.3	15	19.3	21.6	28.5	0.21
POS 18	18	M18×1.5	23	16.5	45	44	72	94	31.75	0.3	15	21.8	26.0	42.5	0.28
POS 20	20	M20×1.5	25	18	48	48	78	102	34.925	0.3	14	24.3	31.5	52.5	0.38
POS 22	22	M22×1.5	28	20	52	54	84	111	38.10	0.3	5	25.8	38.0	57.0	0.48
POS 25	25	M24×2	31	22	58	60	94	124	42.85	0.3	5	29.5	47.5	68.0	0.64
POS 28	28	M27×2	35	24	63	66	103	136	47.6	0.3	15	32.7	58.0	75.0	0.96
POS 30	30	M30×2	37	25	67	70	110	145	50.8	0.3	17	34.8	64.0	88.0	1.1

For left-hand thread, suffix "L" is added to bearings number and thread sign, e.g. POSL8 M8L-6g

- Bearings with a stretching rod, stretching rod with right or left-hand male thread.
- The design feature of type SABP...S as POS..... is, but dimensions in inch.
- The type SAZJ... is swaged, the dimensions in inch.
- Spherical surface of inner ring with chromium plating, to plate zinc on the surface of rod body.

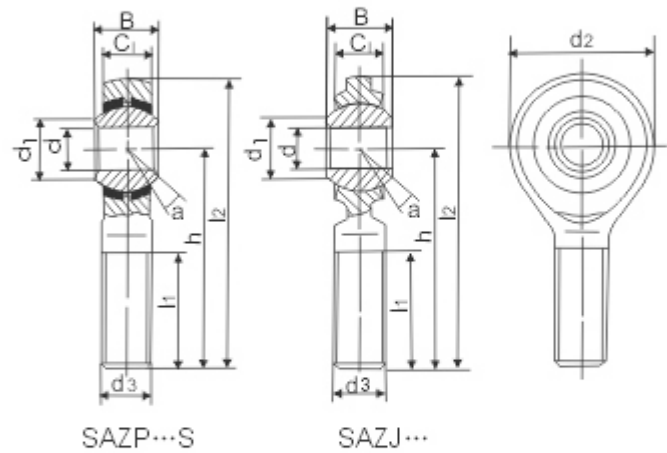

SAZP...S

SAZJ...

Number	Dimensions (mm)										Load Ratings		a° ≈	weight =kg
	d	B	r <sub>10</sub> m/l	C <sub>1</sub> max	d <sub>1</sub> m/l	d <sub>2</sub> max	d <sub>3</sub>	h	l <sub>1</sub> max	l <sub>2</sub> max	C	Co		
SAZP 4S	4.83	7.92	0.3	6.35	7.8	15.88	10-32	31.75	19.05	39.70	3.4	3.8	10	0.013
SAZP 6S	6.35	9.53	0.3	7.14	8.4	19.05	1/4-28	39.67	25.40	49.20	4.5	6.6	13	0.022
SAZP 7S	7.94	11.10	0.3	8.74	11.4	22.23	5/16-24	47.63	31.75	58.72	6.9	8.4	10	0.037
SAZP 9S	9.53	12.70	0.6	10.31	13.1	25.40	3/8-24	49.23	31.75	61.93	9.4	10	9	0.055
SAZP 11S	11.11	14.27	0.6	11.10	14.9	28.58	7/16-20	53.98	34.93	68.28	11	13	11	0.078
SAZP 12S	12.70	15.88	0.6	12.70	17.7	33.32	1/2-20	61.93	38.10	78.59	15	19	9	0.12
SAZP 15S	15.88	19.05	0.6	14.27	21.3	38.10	5/8-18	66.68	41.28	85.73	20	21	11	0.18
SAZP 19S	19.05	22.23	0.6	17.45	24.8	44.45	3/4-16	73.03	44.45	95.25	29	29	10	0.29
SAZP 25S	25.40	34.93	0.6	25.40	32.2	69.85	5/4-12	104.78	53.98	139.70	60	101	14	1.1
SAZJ 4※	4.83	7.92	0.3	5.94	7.8	15.88	10-32	31.75	19.05	39.70	3.6	3.8	10	0.014
SAZJ 6※	6.35	9.53	0.3	6.35	8.4	19.05	1/4-28	39.67	25.40	49.20	54	6.6	13.5	0.018
SAZJ 7※	7.94	11.10	0.3	7.92	11.4	22.23	5/16-24	47.63	31.75	58.72	8.5	12	11	0.032
SAZJ 9	9.53	12.70	0.6	9.12	13.1	25.40	3/8-24	49.23	31.75	61.93	11	16	11	0.050
SAZJ 11	11.11	14.27	0.6	10.31	14.9	28.58	7/16-20	53.98	34.93	68.28	14	21	10.5	0.068
SAZJ 12	12.70	15.88	0.6	11.50	17.7	33.32	1/2-20	61.93	38.10	78.59	18	28	10	0.11
SAZJ 15	15.88	19.05	0.6	12.29	21.3	38.10	5/8-18	66.68	41.28	85.73	23	29	13	0.16
SAZJ 19	19.05	22.23	0.6	15.06	24.8	44.45	3/4-16	73.03	44.45	95.25	34	44	12	0.26

For left-hand thread, suffix "L" is added to bearings number and suffix "LH" is added to thread sign, e.g. SALZJ9 3/8-24-3ALH, 3/8-24-3ALH.

※ A lubrication hole or a grease nipple is not supplied on these sizes, when a grease nipple is required use the sign of SAZJ...S.



- Bearings with a stretching rod, stretching rod with right or left-hand female thread.
- The design feature of type SIZP...S as PHS....., but dimensions in inch.
- The type SIZJ... is swaged, the dimensions in inch. Spherical surface of inner ring with chromium plating, to plate zinc the surface of rod body.

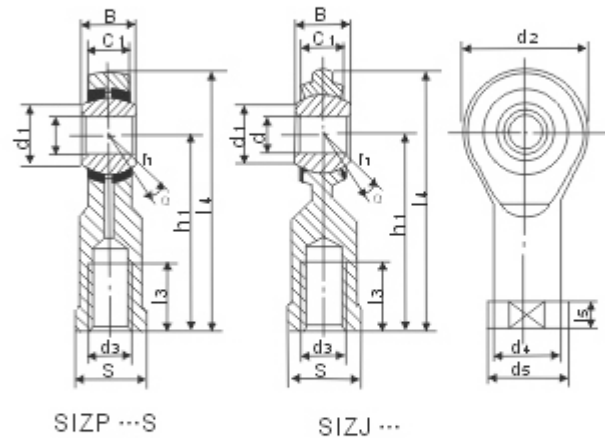

Number	Dimensions (mm)															Load Ratings KN		a°	weight =kg
	d	B	r <sub>ms</sub> m/ls	C <sub>1</sub> max	d <sub>1</sub> m/ls	d <sub>2</sub> m/ls	d <sub>3</sub> max	h <sub>1</sub>	l <sub>2</sub> m/ls	l <sub>3</sub> max	l <sub>5</sub> max	d <sub>4</sub> max	d <sub>5</sub> max	S	C	Co			
SIZP 4S	4.83	7.92	0.3	6.35	7.8	15.88	10-32	26.97	14.27	34.93	4.75	7.54	10.31	7.92	3.4	4.6	10	0.015	
SIZP 6S	6.35	9.53	0.3	7.14	8.4	19.05	1/4-28	33.32	19.05	42.85	4.75	9.15	11.91	9.53	4.5	7.7	13	0.025	
SIZP 7S	7.94	11.10	0.3	8.74	11.4	22.23	5/16-24	34.93	19.05	46.02	4.75	10.27	12.70	11.10	6.9	8.4	10	0.036	
SIZP 9S	9.53	12.70	0.6	10.31	13.1	25.40	3/8-24	41.28	23.80	53.98	6.35	13.89	17.45	14.27	9.4	10	9	0.061	
SIZP 11S	11.11	14.27	0.6	11.10	14.9	28.58	7/16-20	46.02	26.97	60.33	6.35	15.49	19.05	15.88	11	13	11	0.081	
SIZP 12S	12.70	15.88	0.6	12.70	17.7	33.32	1/2-20	53.98	30.15	70.64	6.35	18.67	22.23	19.05	15	19	9	0.133	
SIZP 15S	15.88	19.05	0.6	14.27	21.3	38.10	5/8-18	63.50	38.10	83.55	7.92	21.84	25.40	22.23	20	21	11	0.190	
SIZP 19S	19.05	22.23	0.6	17.45	24.8	44.45	3/4-16	73.0	44.45	95.25	7.92	25.02	28.58	25.04	29	29	10	0.285	
SIZP 25S	25.40	34.93	0.6	25.40	32.2	69.85	5/4-12	104.78	53.98	139.70	11.10	37.72	44.45	38.10	60	101	14	1.00	
SIZJ 4※	4.83	7.92	0.3	5.94	7.8	15.88	10-32	26.97	12.70	34.93	4.75	7.54	10.31	7.92	3.6	6.8	10	0.018	
SIZJ 6※	6.35	9.53	0.3	6.35	8.4	19.05	1/4-28	33.32	15.88	42.85	4.75	9.15	11.91	9.53	54	9.6	13.5	0.023	
SIZJ 7※	7.94	11.10	0.3	7.92	11.4	22.23	5/16-24	34.93	15.88	46.02	4.75	10.72	12.70	11.10	8.5	12	11	0.036	
SIZJ 9	9.53	12.70	0.6	9.12	13.1	25.40	3/8-24	41.28	19.05	53.98	6.35	13.89	17.45	14.27	11	16	11	0.059	
SIZJ 11	11.10	14.27	0.6	10.31	14.9	28.58	7/16-20	46.02	22.23	60.33	6.35	15.49	19.05	15.88	14	21	10.5	1.082	
SIZJ 12	12.70	15.88	0.6	11.50	17.7	33.32	1/2-20	53.98	25.40	70.64	6.35	18.67	22.23	19.05	18	28	10	0.132	
SIZJ 15	15.88	19.05	0.6	12.29	21.3	38.10	5/8-18	63.50	31.75	82.55	7.92	21.84	25.40	22.23	23	29	13	0.195	
SIZJ 19	19.05	22.23	0.6	15.06	24.8	44.45	3/4-16	73.03	34.93	95.25	7.92	25.02	28.58	25.40	34	44	12	0.295	

For left-hand thread, suffix "L" is added to bearing number and suffix "LH" is added to thread sign, e.g. SILZP15 5/8-18-3BLH.

※ A lubrication hole or a grease nipple is not supplied on these sizes, when a grease nipple is required use the sign of SIZJ...S.

- Bearings with a stretching rod, with female thread clamping arrangement, the thread is right or left-hand .
- The type GIHR-K...DO is made up of a spherical plain bearing of type GE...ES and rod body.
- The housing with a lubrication hole or a grease nipple.

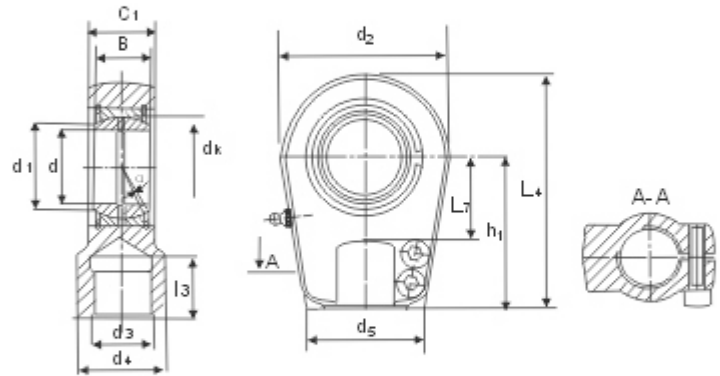

Number	Dimensions (mm)															Load Ratings		weight =kg
	d	d <sub>3</sub>	d <sub>4</sub>	$\frac{l_3}{mm}$	B	C <sub>1</sub>	$\frac{d_2}{max}$	$\frac{l_1}{mm}$	h <sub>1</sub>	l <sub>4</sub>	d <sub>5</sub>	d <sub>1</sub>	d <sub>k</sub>	$\alpha^\circ$	C	C <sub>0</sub>		
GIHR-K 20 DO	20	M16×1.5	25	17	16	19	56	25	50	78	41	24.1	29	9	30.0	72.0	0.43	
GIHR-K 25 DO	25	M16×1.5	25	17	20	23	56	25	50	78	41	29.3	35.5	7	48.0	72.0	0.48	
GIHR-K 30 DO	30	M22×1.5	32	23	22	28	64	30	60	92	46	34.2	40.7	6	62.0	106	0.74	
GIHR-K 35 DO	35	M28×1.5	40	29	25	30	78	38	70	109	58	39.7	47	6	80.0	153	1.2	
GIHR-K 40 DO	40	M35×1.5	49	36	28	35	94	45	85	132	66	45	53	7	100	250	2.0	
GIHR-K 50 DO	50	M45×1.5	61	46	35	40	116	55	105	163	88	55.9	60	6	156	365	3.8	
GIHR-K 60 DO	60	M58×1.5	75	59	44	50	130	65	130	200	90	66.8	66	6	245	400	5.4	
GIHR-K 70 DO	70	M65×1.5	86	66	49	55	154	75	150	232	100	77.8	80	6	315	540	8.5	
GIHR-K 80 DO	80	M80×2	102	81	55	60	176	80	170	165	125	80.4	92	6	400	670	12.0	
GIHR-K 90 DO	90	M100×2	124	101	60	65	206	90	210	323	146	98	105	5	490	980	21.5	
GIHR-K 100 DO	100	M110×2	138	111	70	70	230	105	235	360	166	109.5	115	7	610	1120	27.5	
GIHR-K 110 DO	110	M120×3	152	125	70	80	265	115	265	407.5	190	121.2	130	6	655	1700	40.5	
GIHR-K 120 DO	120	M130×3	172	135	85	90	340	140	310	490	217	135.5	160	6	950	2900	76	

For left-hand thread, suffix "L" is added to bearings number and thread sign, e.g. GIHL-K30DO M22X1.5 -6H.

- Bearings with a stretching rod, with female thread clamping arrangement, the thread is right or left-hand.
- The type GIHR-K...DO is made up of a spherical plain bearing of type GE...ES and rod body.
- The housing with a lubrication hole or a grease nipple.

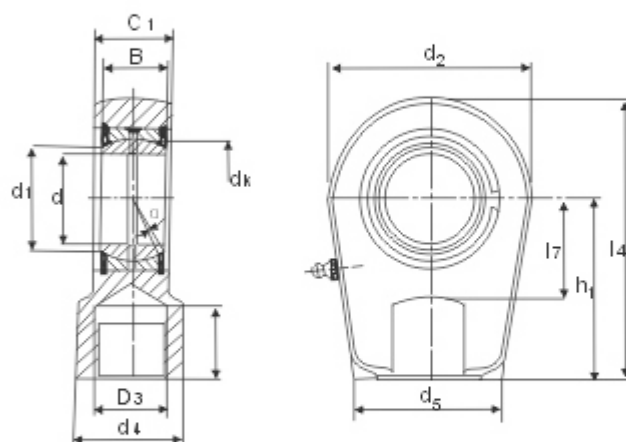

Number	Dimensions (mm)															Load Ratings		weight =kg
	d	d <sub>1</sub>	d <sub>2</sub>	$\frac{l_1}{mm}$	B	C <sub>1</sub>	d <sub>2</sub>	$\frac{l_2}{mm}$	h <sub>1</sub>	l <sub>4</sub>	D <sub>3</sub>	d <sub>4</sub>	d <sub>k</sub>	$\alpha^\circ$	C	C <sub>0</sub>		
GIHR 20 DO	20	M16×1.5	25	17	16	19	56	25	50	78	41	24.1	29	9	30.0	72.0	0.43	
GIHR 25 DO	25	M16×1.5	25	17	20	23	56	25	50	78	41	29.3	35.5	7	48.0	72.0	0.48	
GIHR 30 DO	30	M22×1.5	32	23	22	28	64	30	60	92	46	34.2	40.7	6	62.0	106	0.74	
GIHR 35 DO	35	M28×1.5	40	29	25	30	78	38	70	109	58	39.7	47	6	80.0	153	1.2	
GIHR 40 DO	40	M35×1.5	49	36	28	35	94	45	85	132	66	45	53	7	100	250	2.0	
GIHR 50 DO	50	M45×1.5	61	46	35	40	116	55	105	163	88	55.9	60	6	156	365	3.8	
GIHR 60 DO	60	M58×1.5	75	59	44	50	130	65	130	200	90	66.8	66	6	245	400	5.4	
GIHR 70 DO	70	M65×1.5	86	66	49	55	154	75	150	232	100	77.8	80	6	315	540	8.5	
GIHR 80 DO	80	M80×2	102	81	55	60	176	80	170	165	125	80.4	92	6	400	670	12.0	
GIHR 90 DO	90	M100×2	124	101	60	65	206	90	210	323	146	98	105	5	490	980	21.5	
GIHR 100 DO	100	M110×2	138	111	70	70	230	105	235	360	166	109.5	115	7	610	1120	27.5	
GIHR 110 DO	110	M120×3	152	125	70	80	265	115	265	407.54	190	121.2	130	6	655	1700	40.5	
GIHR 120 DO	120	M130×3	172	135	85	90	340	140	310	490	217	135.5	160	6	950	2900	76	

For left-hand thread, suffix "L" is added to bearings number and thread sign, e.g. GIHL40DO M35X1.5L-6H.

- Bearings with a stretching rod, with female thread clamping arrangement, the thread is right or left-hand .
- The type SIQG...ES is made up of a spherical plain radial bearing of type GE...LO and rod body.
- The housing with a lubrication hole or a grease nipple.

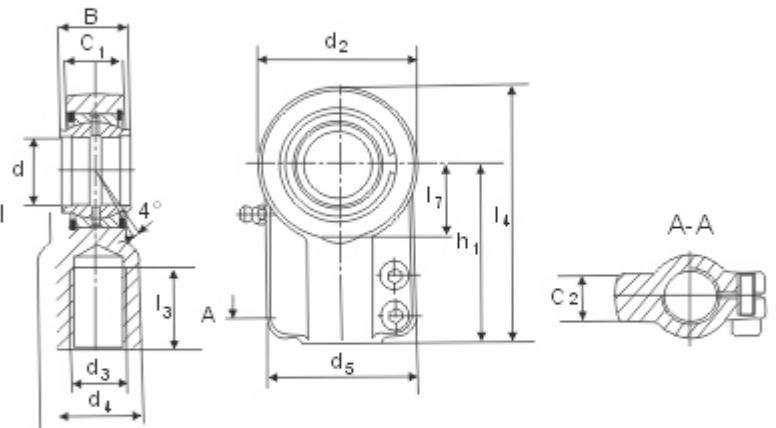

Number	Dimensions (mm)												Load Ratings		weight =kg
	d	B	C <sub>1</sub>	d <sub>3</sub>	d <sub>4</sub>	$l_{mb}$	d <sub>2</sub>	L <sub>1</sub>	h <sub>1</sub>	L <sub>7</sub>	C <sub>2</sub>	D <sub>5</sub>	C	C <sub>0</sub>	
SIQG 12 E※	12	12	10.6	M12×1.25	16.5	17	32	54	38	14	10.6	32	10.8	24.5	0.10
SIQG 16 ES	16	16	13	M14×1.5	21	19	40	64	44	18	13	40	17.6	36.5	0.20
SIQG 20ES	20	20	17	M16×1.5	25	23	47	75.2	52	22	17	47	30.0	48.0	0.40
SIQG 25 ES	25	25	21	M20×1.5	30	29	58	94	65	27	17	54	48.0	78.0	0.66
SIQG 32ES	32	32	27	M27×2	38	37	70	115	80	32	22	66	67.0	114	1.20
SIQG 40ES	40	40	32	M33×2	47	46	89	141.2	97	41	26	80	100	204	2.1
SIQG 50 ES	50	50	40	M42×2	58	57	108	174	120	50	32	96	156	310	4.4
SIQG 63 ES	63	63	52	M48×2	70	64	132	211	140	62	38	114	255	430	7.6
SIQG 70 ES	70	70	57	M56×2	80	76	155	245	160	70	42	135	315	540	9.5
SIQG 80 ES	80	80	66	M64×2	90	86	168	270	180	78	48	148	400	695	14.5
SIQG 90 ES	90	90	72	M72×3	100	91	185	296	195	85	52	160	490	750	17.0
SIQG 100 ES	100	100	84	M80×3	110	96	210	322	210	98	62	178	610	1060	28.0
SIQG 110 ES	110	110	88	M90×3	125	106	235	364	235	105	62	190	655	1200	32.0
SIQG 125 ES	125	125	102	M100×3	135	113	262	405	260	120	72	200	950	1430	43.0

For left-hand thread, suffix "L" is added to bearings number and suffix "LH" is added to thread sign, e.g. SIQG32ES M27x2L -6H

※ Relubrication not possible.

- Bearings stretching rod or housing is made of weldable steel.
- The type GF...DO is made up of a spherical plain bearing of type GE...ES and housing with a rectangular welding face.

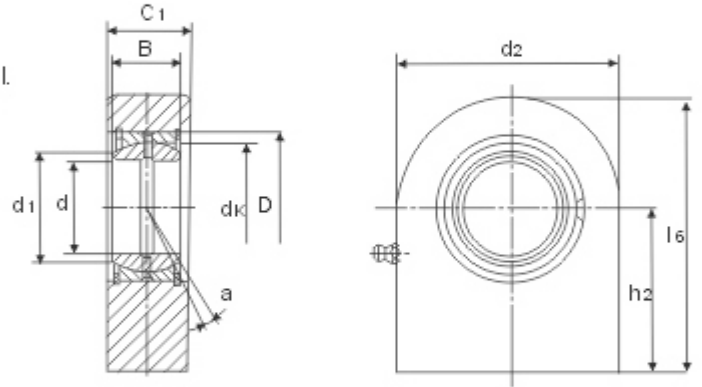

Number	Dimensions (mm)									Load Ratings		weight =kg
	d	C <sub>1</sub>	B	d <sub>k</sub>	l <sub>6</sub>	h <sub>2</sub>	d <sub>k</sub>	d <sub>1</sub>	D	C	Co	
GF 20 DO	20	19 <sup>+0.0</sup> <sub>0</sub>	16	50	63	38	29	24.1	35	30.0	67.0	0.35
GF 25 DO	25	23 <sup>+0.0</sup> <sub>0</sub>	20	55	72.5	45	35.5	29.3	42	48.0	69.5	0.53
GF 30 DO	30	28 <sup>+0.0</sup> <sub>0</sub>	22	65	83.5	51	40.7	34.2	47	62.0	118	0.87
GF 35 DO	35	30 <sup>+0.0</sup> <sub>0</sub>	25	83	102.5	61	47	39.7	55	80.0	196	1.5
GF 40 DO	40	35 <sup>+0.0</sup> <sub>0</sub>	28	100	119	69	53	45	62	100	300	2.4
GF 45 DO	45	40 <sup>+0.0</sup> <sub>0</sub>	32	110	132	77	60	50.7	68	127	380	3.4
GF 50 DO	50	40 <sup>+0.0</sup> <sub>0</sub>	35	123	149.5	88	66	55.9	75	156	440	4.4
GF 60 DO	60	50 <sup>+0.0</sup> <sub>0</sub>	44	140	170	100	80	66.8	90	245	570	7.1
GF 70 DO	70	55 <sup>+0.0</sup> <sub>0</sub>	49	164	197	115	92	77.8	105	315	695	10.5
GF 80 DO	80	60 <sup>+0.0</sup> <sub>0</sub>	55	180	231	141	105	89.4	120	400	780	15.0
GF 90 DO	90	65 <sup>+0.0</sup> <sub>0</sub>	60	226	263	150	115	98.1	130	490	1340	23.5
GF 100 DO	100	70 <sup>+0.0</sup> <sub>0</sub>	70	250	295	170	130	109.5	150	610	1500	31.5
GF 110 DO	110	80 <sup>+0.0</sup> <sub>0</sub>	70	295	332.5	185	140	121.2	160	655	2160	48.5
GF 120 DO	120	90 <sup>+0.0</sup> <sub>0</sub>	85	360	390	210	160	135.5	180	950	3250	79

Also made up of a spherical radial bearings with two seals and rod body, e.g. GF 70 DO-2RS

- Bearing's stretching rod or housing is made of weldable steel.
- The type GK...DO is made up of a spherical plain bearing of type GE...ES and a stretching rod with welding slope, there is dowel pin at the end of the rod.

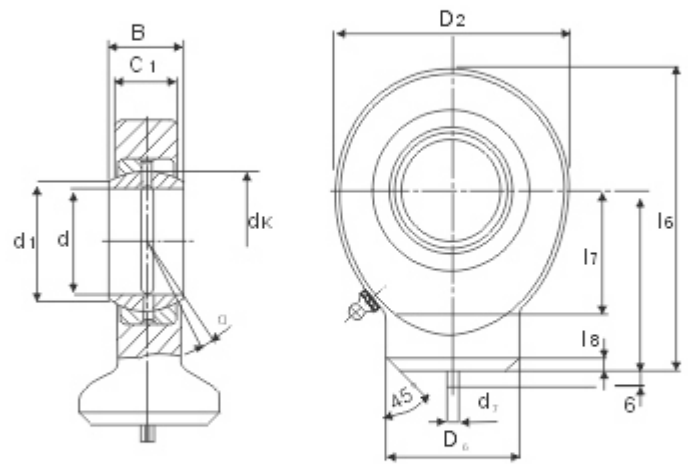

Number	Dimensions (mm)														Load Ratings		weight =kg
	d	d <sub>1</sub>	B	C <sub>1</sub>	d <sub>k</sub>	d <sub>2</sub>	l <sub>6</sub>	h <sub>2</sub>	l <sub>7</sub>	l <sub>8</sub>	d <sub>1</sub>	d <sub>2</sub>	D	a°	C	Co	
GK 10 DO	10	13.2	9	7	16	29	38.5	24	15	2	3	15	19	12	8.15	15.6	0.041
GK 12 DO	12	14.9	10	8	18	34	44	27	18	2	3	17.5	22	11	10.8	21.6	0.066
GK 15 DO	15	18.4	12	10	22	40	51	31	20	2.5	4	21	26	8	17.0	32.0	0.12
GK 17 DO	17	20.7	14	11	25	46	58	35	23	3	4	24	30	10	21.2	40.0	0.19
GK 20 DO	20	24.1	16	13	29	53	64.5	27	27	3	4	27.5	35	9	30.0	54.0	0.23
GK 25 DO	25	29.3	20	17	35.5	64	77	32	32	4	4	33.5	42	7	48.0	72.0	0.43
GK 30 DO	30	34.2	22	19	40.7	73	87.5	37	37	4	4	40	47	6	62.0	95.0	0.64
GK 35 DO	35	39.7	25	21	47	82	102	42	42	4	4	47	55	6	80.0	125	0.96
GK 40 DO	40	45	28	23	53	92	115	48	48	5	4	52	62	7	100	156	1.3
GK 45 DO	45	50.7	32	27	60	102	128	52	52	5	6	58	68	7	127	208	1.8
GK 50 DO	50	55.9	35	30	66	112	144	60	60	6	6	62	75	6	156	250	2.5
GK 60 DO	60	66.8	44	38	80	135	167.5	75	75	8	6	70	90	6	245	390	3.9
GK 70 DO	70	77.8	49	42	92	160	195	87	87	10	6	80	105	6	315	510	6.6
GK 80 DO	80	89.4	47	47	105	180	231	100	100	10	6	95	120	6	400	620	8.7

Also made up of a spherical radial bearings with two seals and rod body, e.g. GK50 DO-2RS



- Ball joint housing is an outer ring of spherical plain radial bearing, made of zinc base alloy.

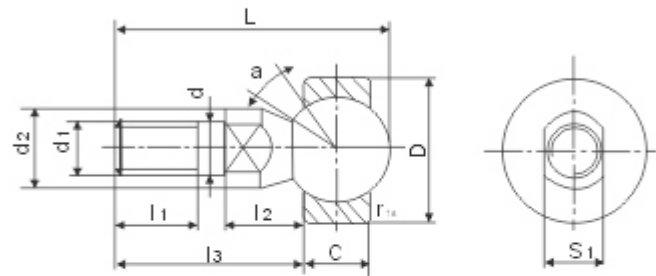

Number	Dimensions (mm)												Load Ratings	weight =kg
	d	d <sub>1</sub>	d <sub>2</sub>	l <sub>min</sub>	l <sub>2</sub>	l <sub>max</sub>	L <sub>max</sub>	S <sub>k</sub>	C	D	r, S mm	a°		
SQD 5	5	M5×0.8	9	8	8	19	27.5	7	6	16	0.3	25	2.0	0.014
SQD 6	6	M6×1	10	11	8/8	23.5	33.5	8	6.75	18	0.3	25	3.2	0.021
SQD 8	8	M8×1.25	12	12	11.6	28.6	41	10	9	22	0.3	25	5.7	0.042
SQD 10	10	M10×1.25	14	15	14.2	34.2	49	11	10.5	26	0.3	25	9.2	0.067
SQD 10-1	10	M10×1.5	14	21	14.2	40.2	55	11	10.5	26	0.3	25	9.2	0.067
SQD 12	12	M12×1.25	17	17	15.1	38.1	55.1	15	12	30	0.5	25	14	0.108
SQD 12-1	12	M12×1.75	17	24	15.1	45.1	62.1	15	12	30	0.5	25	14	0.108
SQD 14	14	M14×1.5	19	22	16.8	51.3	70.7	17	13.5	34	0.5	20	19	0.167
SQD 14-1	14	M14×2	19	28	16.8	57.3	76.7	17	13.5	34	0.5	20	19	0.167
SQD 16	16	M16×1.5	22	23	18	54.4	76.3	19	15	38	0.5	20	26	0.238
SQD 16-1	16	M16×2	22	29	18	60.5	82.3	19	15	38	0.5	20	26	0.238

Applicants:

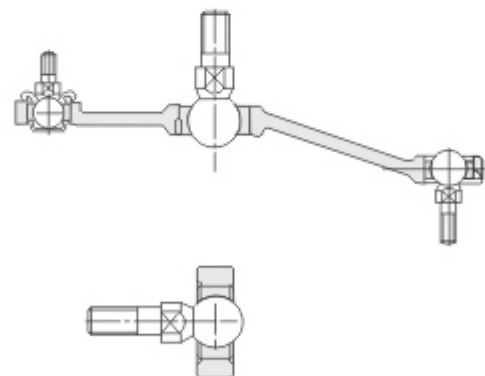
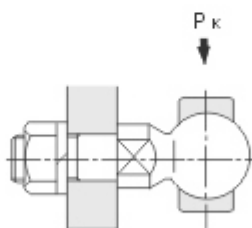



- Ball joint housing is an axial shank with the female thread, it is made up of zinc base alloy, stretching rod with right or left-hand thread.

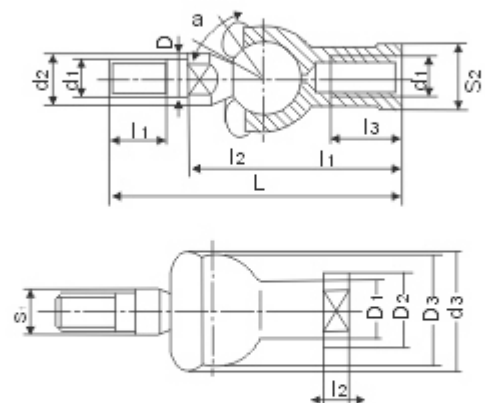

Number	Dimensions (mm)																KN Load Ratings	weight =kg
	d	d <sub>1</sub>	D <sub>2 min</sub>	d <sub>3 max</sub>	l <sub>1 Min</sub>	l <sub>2</sub>	S <sub>1</sub>	L <sub>max</sub>	L	L <sub>2 max</sub>	L <sub>3 min</sub>	D <sub>1 max</sub>	D <sub>2 max</sub>	D <sub>3 max</sub>	S <sub>2</sub>	a		
SQZ 5-RS	5	M5×0.8	9	20	8	11	7	46	24	4	12	9	11	17	9	15	2.8	0.025
SQZ 6-RS	6	M6×1	10	20	11	12.2	8	55.2	28	5	15	10	13	20	11	15	3.7	0.041
SQZ 8-RS	8	M8×1.25	12	24	12	16	10	6.5	32	5	16	12.5	16	24	14	15	5.8	0.075
SQZ 10-RS	10	M10×1.25	14	30	15	19.5	11	74.5	35	6.5	18	15	19	28	17	15	8.4	0.12
SQZ 10-RS-1	10	M10×1.5	14	30	21	19.5	11	80.5	35	6.5	18	15	19	28	17	15	8.4	0.12
SQZ 12-RS	12	M12×1.25	17	32	17	21	15	84	40	6.5	20	17.5	22	32	19	15	11	0.18
SQZ 12-RS-1	12	M12×1.75	17	32	24	21	15	91	40	6.5	20	17.5	22	32	19	15	11	0.18
SQZ 14-RS	14	M14×1.5	19	38	22	23.5	17	103	45	8	25	20	25	36	22	11	15	0.27
SQZ 14-RS-1	14	M14×2	19	38	28	23.5	17	109	45	8	25	20	25	36	22	11	15	0.27
SQZ 16-RS	16	M16×1.5	22	44	23	25.5	19	112	50	8	27	22	27	40	22	11	15	0.36
SQZ 16-RS-1	16	M16×2	22	44	29	25.5	19	118	50	8	27	22	27	40	22	11	15	0.36
SQZ 18-RS	18	M18×1.5	23	45	25	31	20	130.5	58	10	31	25	31	45	27	11	19	0.54
SQZ 20-RS	20	M20×1.5	27	50	25	29	24	133	63	10	34	27.5	34	45	30	7.5	19	0.57
SQZ 22-RS	22	M22×1.5	27	52	26	33	24	145	70	12	37	30	37	50	32	7.5	23	0.76

The shank of ball joint housing may be left-hand thread for left-hand thread. suffix "L" is added to bearings number and thread sign, e.g SQZ15-RS M5L-6H, the bearings number seal is SQZ...



- Ball joint housing is a “L” shaped shank with female thread, it is made up of zinc base alloy, they are available for right or-hand left-hand thread.

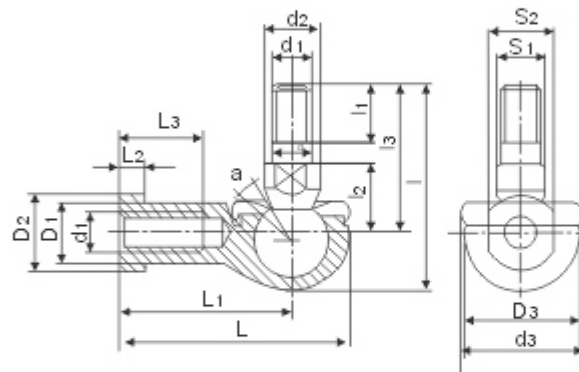

Number	Dimensions (mm)																		KN Load Ratings	weight =kg
	d	d <sub>1</sub>	d <sub>2</sub> m l	d <sub>3</sub> max	l <sub>1</sub> max	l <sub>1</sub> m l	l <sub>2</sub>	l <sub>3</sub> max	S <sub>1</sub>	L <sub>1</sub> max	L <sub>1</sub>	L <sub>2</sub> max	L <sub>2</sub> m l	D <sub>1</sub> max	D <sub>2</sub> max	D <sub>3</sub> max	S <sub>2</sub>	a		
SQ 5-RS	5	M5×0.8	9	19	29	8	10	21	7	35	27	4	14	9	11	16	9	25	2.2	0.026
SQ 6-RS	6	M6×1	10	20	35.5	11	11	26	8	40	30	5	14	10	13	19	11	25	3.5	0.039
SQ 8-RS	8	M8×1.25	12	24	42.5	12	14	31	10	48	36	5	17	12.5	16	23	14	25	6.6	0.068
SQ 10-RS	10	M10×1.25	14	30	50.5	15	17	37	11	57	43	6.5	21	15	19	27	17	25	10	0.112
SQ 10-RS-1	10	M10×1.5	14	30	56.5	21	17	43	11	57	43	6.5	21	15	19	27	17	25	10	0.112
SQ 12-RS	12	M12×1.25	17	32	57.5	17	19	42	15	66	50	6.5	25	17.5	22	31	19	25	16	0.164
SQ 12-RS-1	12	M12×1.75	17	32	64.5	24	19	49	15	66	50	6.5	25	17.5	22	31	19	25	16	0.164
SQ 14-RS	14	M14×1.5	19	38	73.5	22	21.5	56	17	75	57	8	26	20	25	35	22	25	19	0.254
SQ 14-RS-1	14	M14×2	19	38	79.5	28	21.5	62	17	75	57	8	26	20	25	35	22	25	19	0.254
SQ 16-RS	16	M16×1.5	22	44	79.5	23	23.5	60	19	84	64	8	32	22	27	39	22	20	26	0.336
SQ 16-RS-1	16	M16×2	22	44	85.5	29	23.5	66	19	84	64	8	32	22	27	39	22	20	26	0.336
SQ 18-RS	18	M18×1.5	23	45	90	25	26.5	68	20	93	71	10	34	25	31	44	27	20	33	0.464
SQ 20-RS	20	M20×1.5	27	50	90	25	27	68	24	99	77	10	35	27.5	34	44	30	20	45	0.538
SQ 22-RS	22	M22×1.5	27	52	95	26	28	70	24	100	84	12	41	30	37	50	32	16	48	0.713

The shank of ball joint housing may be left-hand thread.for left-hand thread. Suffix “L” is added to bearings number and thread sign,e.g SQL6-RS M6L-6H, the bearings number without seal is SQ...